

Agilent 8761A/B Microwave Switches

Product Overview

Product Description

The Agilent Technologies 8761A and 8761B are single-pole, double-throw coaxial switches with excellent electrical and mechanical characteristics for 50-ohm transmission systems operating from dc to 18 GHz. Both switches feature broadband operation, long life, low SWR, excellent repeatability, and magnetic latching solenoids. The 8761A and 8761B switches are small and lightweight, making them ideal for applications where space is limited. Because of their versatility and excellent electrical performance, they are well suited for automated testing and systems applications. The A version is for 12 to 15 VDC operation, and the B version uses 24 to 30 VDC solenoid drive voltage.

The Agilent 8761A/B Series can be custom configured with any combination of Type-N, SMA, and precision 7-mm connectors, thus enabling the

user to “custom design” a connector arrangement and eliminate the need for connector adapters.

Electrical Performance

These switches have proven reliable in Agilent microwave instrumentation, special purpose test equipment, and many other applications. They have been optimized for broadband operation, high isolation, minimal insertion loss, low SWR, and high repeatability.

High Isolation

High port-to-port isolation is important in applications requiring wide dynamic range such as receiver sensitivity testing. The RF structure designs used for these switches yield the high isolation shown in Figure 1.

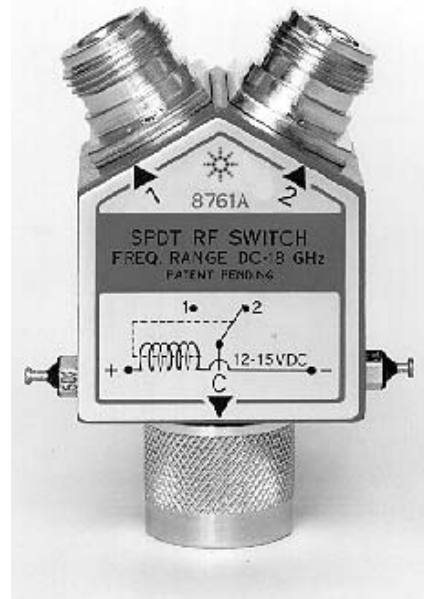

- Broadband (dc to 18 GHz)
- User specified connectors (over 250 possible combinations)
- Excellent repeatability (typically 0.03 dB after 1,000,000 cycles)
- Environmentally rugged



Agilent Technologies

Low Insertion Loss

Low insertion loss is very desirable in many applications where the user needs to minimize the loss of signal power. Using miniature gold-plated contacts, these switches offer the low insertion loss shown in Figure 2.

Low SWR

Low SWR is an important characteristic for switches because transmission line mismatches degrade the measurement system accuracy. Through the use of “edge line” design and precision machining, these switches offer the excellent SWR shown in Figure 3.

High Repeatability

For measurement system applications, repeatability of the switched connection is a key factor in minimizing measurement error. The excellent repeatability of these switches (typically 0.03 dB after one million switching operations) has been achieved by employing gold-plated contacts and edge line design for the transmission line. This unique design feature of switching only the center conductor eliminates high friction sliding contacts, and results in long life and highly repeatable measurements.

The 8761 is a “break before make” switch controlled by a magnetic latching solenoid. Solenoid voltages of 12 and 24 volts are available. The switching signal may be either dc or pulsed; to change the state of the switch requires a reversal of the voltage polarity for at least 20 milliseconds (see Figure 4). Once switched, the solenoid is latched by strong permanent magnets.

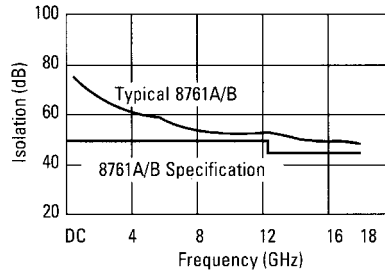

Figure 1. Typical port-to-port isolation

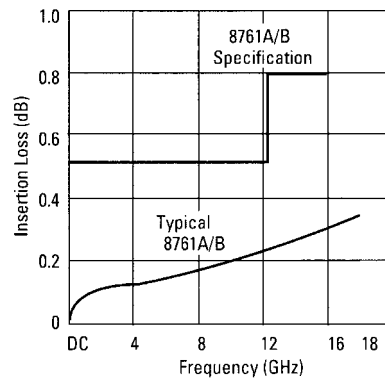

Figure 2. Typical insertion loss

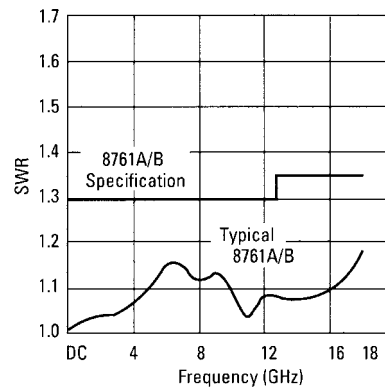

Figure 3. Typical SWR for SMA connection

Typical Agilent 8761A Driver Circuit'

Figure 5 shows a typical driver circuit which uses a clock driver to control the 8761A switch. A TTL “HI” input to the circuit results in +V at point Q and -V (ground) at point R. Conversely, a TTL “LO” input results in -V (ground) at point Q and +V at point R. Internal diodes in the DS0026 suppress inductive voltage spikes.

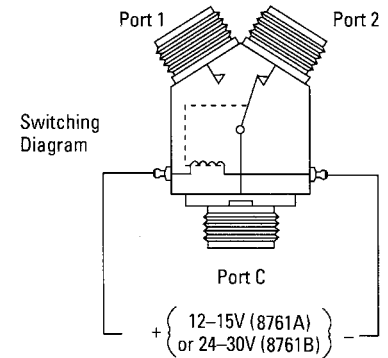
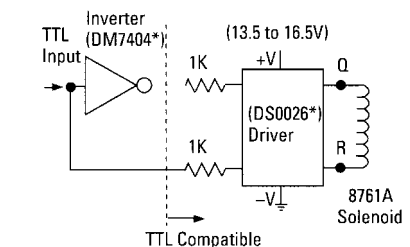

Figure 4. To connect ports 2 and C (as shown) requires the indicated solenoid voltage for at least 20 milliseconds. Reversing the polarity of the solenoid voltage connects ports 1 and C.



*National Semiconductor part numbers, also supplied by other vendors.

Figure 5. Typical 8761A driver circuit

1. Additional circuit design information may be required from the component manufacturer for the circuits described in Figure 5 since modifications may be necessary depending on the specific application. Agilent assumes no responsibility for the use of any circuits described herein and makes no representations or warranties, expressed or implied, that such circuits are free from patent infringement.

Connector Information

The Agilent 8761A/B switches are available with any combination of SMA, Type-N, precision 7-mm (mates with APC-7), and 50-ohm termination. This feature enables the user to custom design a single switch or multiple switch configuration for a specific application. By properly specifying connector options, switch trees can be configured to provide single-pole multi-throw as well as multi-pole multi-throw functions, all without the need for interconnecting cables. To specify connector options, refer to the ordering example.

Three versions of the precision 7-mm connector are available on the 8761A/B which mate with the APC-7 connector, but differ slightly from the standard APC-7 to conserve space. One of these versions (option 102, 202, or 302) has a fixed threaded sleeve and the other (option 103, 203, or 303) has a coupling nut. The third precision 7-mm connector (option 104, 204, or 304) is designed to be used with a 0.250-in. outer diameter, semirigid coaxial cable. This connector is the same as the 7-mm option 102, 202, or 302 connector described above, with the exception of the center conductor which is female and accepts the center conductor of the semi-rigid coax. The fittings for a compatible connector on the semi-rigid coax are shown in Figure 6.

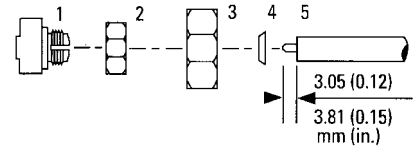

	Part Number
1. Cable Terminator	08742-2028
2. .375-32 Clamp Nut	0590-0035
3. Cable Coupling Nut	08740-2081
4. Cable Washer	5000-8676
5. Semi-rigid Coax Cable, UT-250*	

* Uniform Tubes Inc., Collegeville, PA. Dimensional drawings for items 1 through 4 above are available upon request.

Figure 6. Cable assembly to mate with the 7-mm connector for UT-250 cable (option code 4)

Mechanical Information

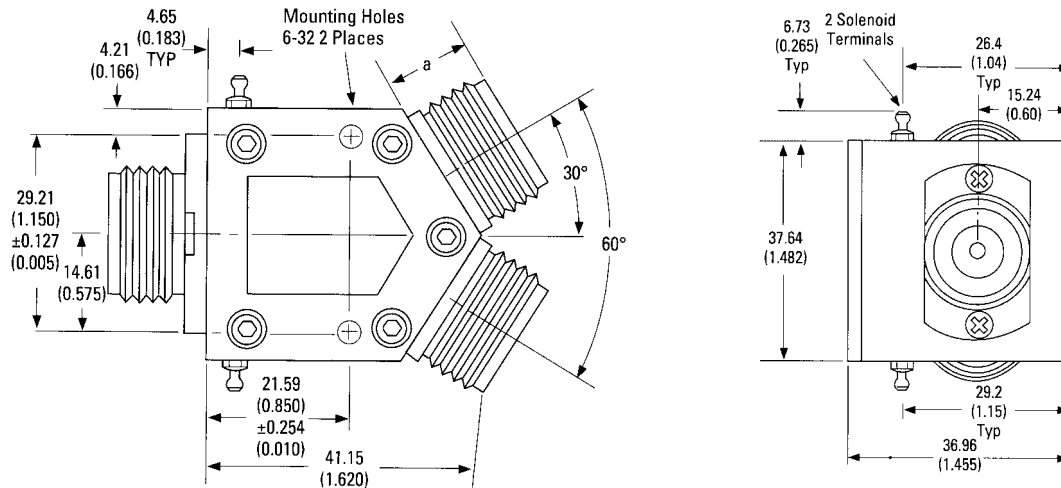

Connector Options

Agilent 8761A/B

Connector

Options	Connector Type	Dimension "a" mm (in.)
100, 200, 300	Type-N Female	13.72 (0.540)
101, 201, 301	Type-N Male	19.79 (0.775)
102, 202, 302	7-mm Threaded Sleeve (APC-7)	9.27 (0.365)
103, 203, 303	7-mm Coupling Nut (APC-7)	11.94 (0.470)
104, 204, 304	7-mm for UT-250 Coax	9.27 (0.365)
105, 205, 305	3-mm Female (SMA)	16.13 (0 @ 635)
106, 206, 306	3-mm Male (SMA)	17.15 (0.675)
107, 207, 307	50-ohm Termination ²	30.5 (1.20)

Replaceable Parts: Refer to the Agilent 8761A/B Operating Note.

2. Option 107, 207 available on port 1 or port 2 only.

Specifications

Switch Type	Single-pole double-throw, break before make, latching solenoid
Frequency Range	DC to 18 GHz
Insertion Loss	DC to 12.4 GHz: <0.5 dB DC to 18.0 GHz: <0.8 dB
Isolation	DC to 12.4 GHz: >50 dB DC to 18.0 GHz: >45 dB
Characteristic Impedance	50 Ω
SWR¹	
Connector Type	
Type N	DC to 12.4 GHz: 1.20 DC to 18.0 GHz: 1.25
7-mm (APC-7)¹	DC to 12.4 GHz: 1.15 DC to 18.0 GHz: 1.20
3-mm (SMA)	DC to 12.4 GHz: 1.30 DC to 18.0 GHz: 1.35
50 Ω Load	SWR degraded by 0.05 when used with above connector types.
Input Power Rating	10 watts average, 5 k watts peak (2 watts average, 100 watts peak with option 7, 50-ohm termination)
Life	>1,000,000 switchings
Repeatability	0.03 dB after 1,000,000 switchings (Typical)
Switching Speed	Maximum: 50 milliseconds
Coil Voltage	8761A: 12 V (12 to 15 V) 8761B: 26 V (24 to 30 V)
Switching Current	8761A: 80 mA @ 12 V 8761B: 65 mA @ 26 V
Coil Impedance	8761A: 150 Ω, 90 mH 8761B: 400 Ω, 300 mH

Environmental Qualifications

Operating Temp.	-25°C to +70°C
Humidity	95% RH, +40°C, 5 days
Vibration	0.03", 10 to 55 Hz
Shock	30 G's, 11 ms
Weight	Net: 140 to 220 gm (5 to 8 oz) Shipping: 220 to 300 gm (8 to 11 oz)

- 8761A/B SWR specifications apply when all ports are of the same connector type. For mixed connector types, the larger of the two SWR's applies. Type-N connector SWR specifications apply to 7-mm for UT-250 Coax connectors (option 104, 204, or 304).
- Either option will connect to a standard, sexless, 7-mm connector. To daisy-chain two 8761A's you must use one option 102, 202, or 302 and one option 103, 203, or 303 on the two mating connectors. If you have two of the same options, you will need to use a cable with two standard 7-mm connectors.

Ordering Information

To order the Agilent 8761A/B switch, connector configuration and solenoid voltage must be specified as shown in the ordering example below.

Connector Options	Connector Type
100, 200, 300	Type-N Female
101, 201, 301	Type-N Male
102, 202, 302	7-mm Threaded Sleeve (APC-7) ²
103, 203, 303	7-mm Coupling Nut (APC-7) ³
104, 204, 304	7-mm for UT-250 Coax
105, 205, 305	3-mm Female (SMA)
106, 206, 306	3-mm Male (SMA)
107, 207, 307	50-ohm Termination

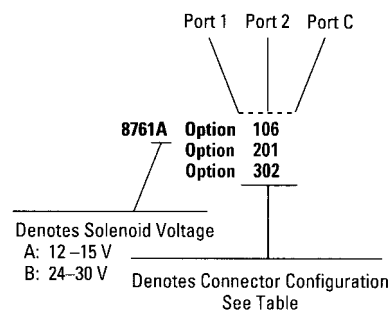
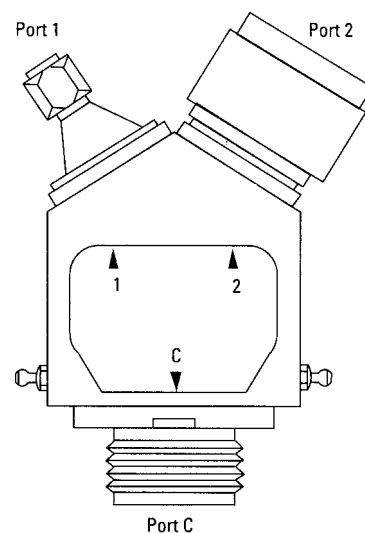



Agilent Email Updates

www.agilent.com/find/emailupdates

Get the latest information on the products and applications you select.



Agilent Direct

www.agilent.com/find/agilentdirect

Quickly choose and use your test equipment solutions with confidence.



www.agilent.com/find/open

Agilent Open simplifies the process of connecting and programming test systems to help engineers design, validate and manufacture electronic products. Agilent offers open connectivity for a broad range of system-ready instruments, open industry software, PC-standard I/O and global support, which are combined to more easily integrate test system development.

Agilent Technologies' Test and Measurement Support, Services, and Assistance

Agilent Technologies aims to maximize the value you receive, while minimizing your risk and problems. We strive to ensure that you get the test and measurement capabilities you paid for and obtain the support you need. Our extensive support resources and services can help you choose the right Agilent products for your applications and apply them successfully. Every instrument and system we sell has a global warranty. Two concepts underlie Agilent's overall support policy: "Our Promise" and "Your Advantage."

Our Promise

Our Promise means your Agilent test and measurement equipment will meet its advertised performance and functionality. When you are choosing new equipment, we will help you with product information, including realistic performance specifications and practical recommendations from experienced test engineers. When you receive your new Agilent equipment, we can help verify that it works properly and help with initial product operation.

Your Advantage

Your Advantage means that Agilent offers a wide range of additional expert test and measurement services, which you can purchase according to your unique technical and business needs. Solve problems efficiently and gain a competitive edge by contracting with us for calibration, extra-cost upgrades, out-of-warranty repairs, and onsite education and training, as well as design, system integration, project management, and other professional engineering services. Experienced Agilent engineers and technicians worldwide can help you maximize your productivity, optimize the return on investment of your Agilent instruments and systems, and obtain dependable measurement accuracy for the life of those products.

www.agilent.com

For more information on Agilent Technologies' products, applications or services, please contact your local Agilent office. The complete list is available at:

www.agilent.com/find/contactus

Phone or Fax

United States:

(tel) 800 829 4444

(fax) 800 829 4433

Canada:

(tel) 877 894 4414

(fax) 800 746 4866

China:

(tel) 800 810 0189

(fax) 800 820 2816

Europe:

(tel) 31 20 547 2111

Japan:

(tel) (81) 426 56 7832

(fax) (81) 426 56 7840

Korea:

(tel) (080) 769 0800

(fax) (080)769 0900

Latin America:

(tel) (305) 269 7500

Taiwan:

(tel) 0800 047 866

(fax) 0800 286 331

Other Asia Pacific Countries:

(tel) (65) 6375 8100

(fax) (65) 6755 0042

Email: tm_ap@agilent.com

Contacts revised: 05/27/05

Product specifications and descriptions in this document subject to change without notice.

© Agilent Technologies, Inc. 1995, 2000, 2002

Printed in USA, May 31, 2006

5952-1911



Agilent Technologies